



Legacy 90

Advanced Traditional Barber's Chair

Retro Redefined. Introducing Legacy 90, by Takara Belmont

Bringing back the nostalgia of the traditional Barbershop, while at the same time offering the quality you can expect from a product made by Takara, is the Legacy 90 barber-chair.

Made in Japan, the Legacy 90 offers features that make a barber or stylist's job easier while offering supreme comfort to every client.





Legacy 90

Red

Hydraulic Base

Legacy 90 on hydraulic base

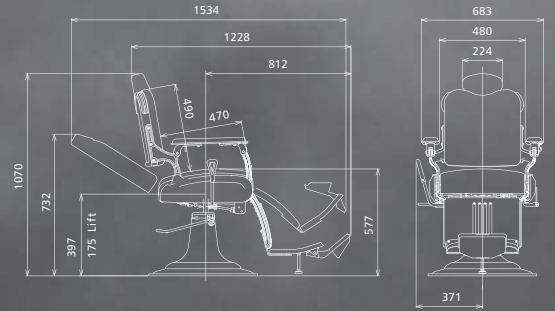

•Weight: 84kg



Legacy 90 Barber Chair in Red, Metallic Silver Chair Frame on Hydraulic Base

Chair Frame



White



Metallic Silver(Upgrade Option)

Standard Accessories



Headrest Holder



Dryer Holder
(Optional in some countries)

Legacy 90 on motorized base

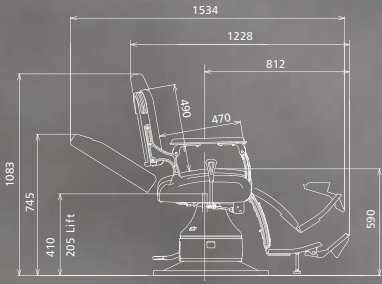

Black

▪ Motorized Base ▪

- Weight: 100kg
- Rated Voltage: 110/120/220/230/240V
- Rated Frequency: 50/60Hz
- Rated Power Consumption: 420W



Legacy 90 Barber Chair in Black, White Chair Frame on Motorized Base

Upgrade Accessories



Manicure Bowl / Holder



Additional Reclining Lever (Left)



Cape Holder



Upholstered Headrest Cover



Towel Hanger



since 1921

TAKARA BELMONT

Tel. +81-6-6212-3523 e-mail: beauty@takara-net.com
<https://beauty.takarabelmont.co.jp>

Takara Belmont is the world's leading designer and manufacturer of salon and spa equipment. Since it started trading in 1921, the corporation has become a leading innovator in the hairdressing, beauty and barber markets. Today, the Takara Belmont Group has more than 20 affiliated companies with more than 80 offices and over 1,400 employees worldwide.

It is our culture to provide the highest levels of service with an intense focus on creating functional, well-designed products of the highest possible quality. This commitment to excellence and service is what has made Takara Belmont a recognized international brand that professionals in our markets remember and associate with our core values.

Technology plays a key role in our success, with the evolution of our barber chairs as a prime example. In 1962 Takara became the first hairdressing equipment manufacturer in the world to apply electric lift technology to barber chairs. Today, we are known for integrating the most advanced technology into ergonomically-designed chairs that ensure a remarkable experience for both barbers and their customers.

Takara Belmont is dedicated to continuing its legacy by maintaining its role as an innovator in the men's grooming market. It is dedicated to pushing the limits with the continued development of new and exciting products.